

A (2:3)

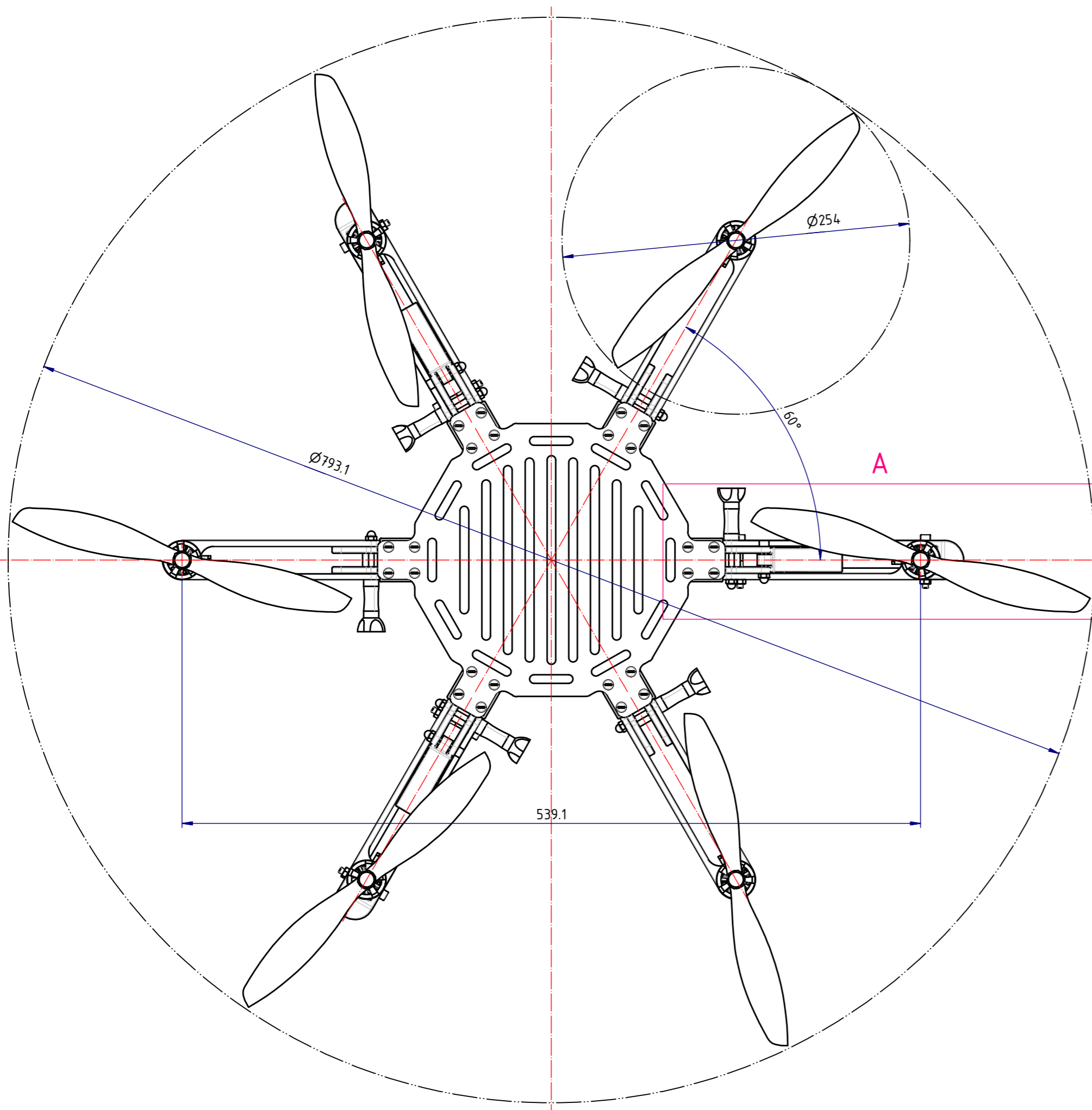

13	GB/T 70.1 M3 x 10	24	GB/T 70.1-2000
12	motor	6	
11	GB 923 M4	9	GB/T 923-1988
10	GB/T 65 M4 x 10	48	GB/T 65-2000
9	GB/T 70.1 M4 x 25	3	GB/T 70.1-2000
8	GB/T 70.1 M4 x 35	6	GB/T 70.1-2000
7	GB/T 6170 M4	6	GB/T 6170-2000
6	pivot screw long	6	
5	leg	3	
4	arm	6	
3	Fingelli L16 50mm Assembly	3	
2	shoulder	6	
1	base	2	

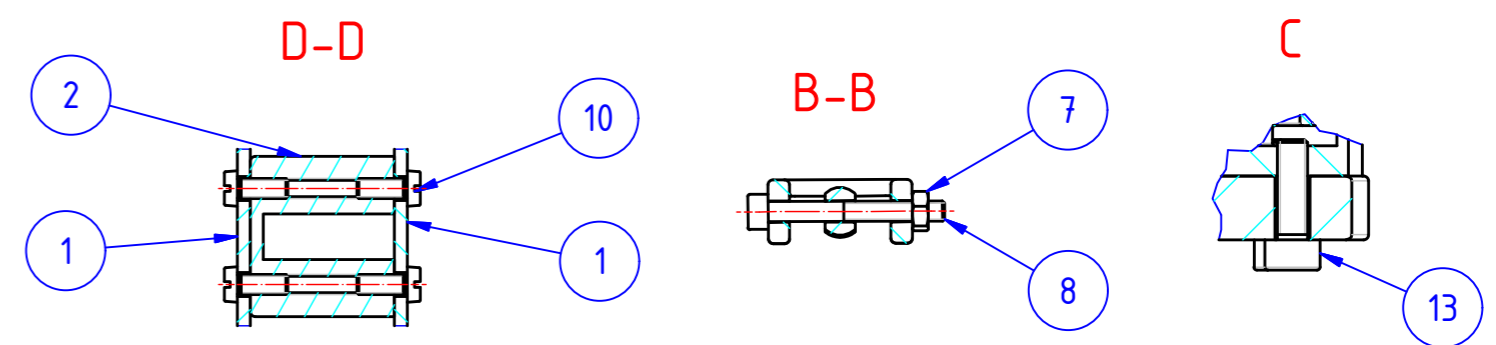
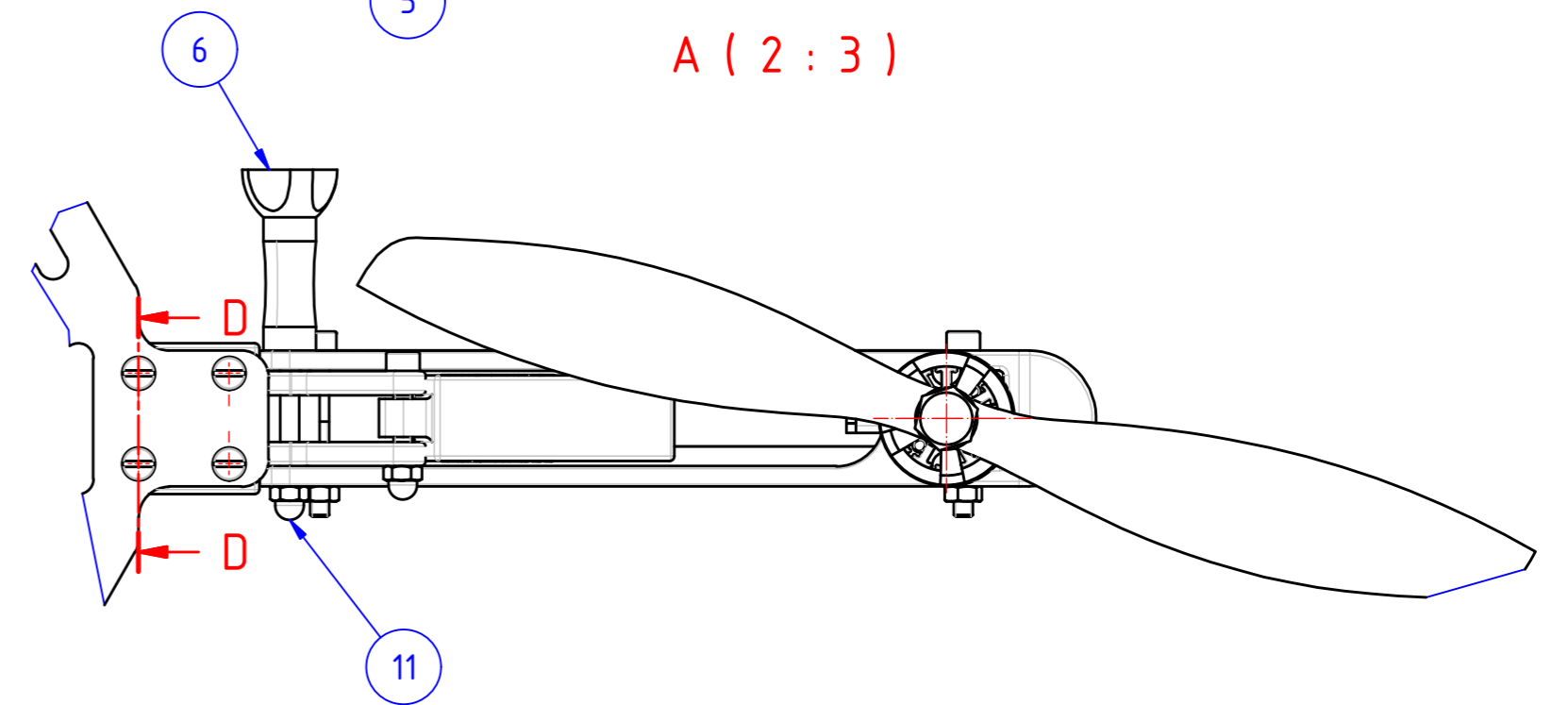

Subject: Drone UAV Design			PROJECTION: OR	
Scale: 1:3	Unit: mm	Paper: A2	Material:	
Drawn/Design by: YongYe Yuan			Date: 2015/7/1	
Title: WareDrone			Page: 1:1	